

# For that different sound, Music a la Theremin

By Louis E. Garner, Jr.

Published November 1967, Popular Electronics

For about the price of an inexpensive guitar, plus a few hours assembly time, you can own and enjoy what is perhaps one of the most versatile of all musical instruments: the unique and amazing theremin. Named after its Russian-born inventor, Leon Theremin, its frequency range exceeds that of all other instruments, including theater pipe organs, while its dynamic range is limited only by the power capabilities of the amplifier and speaker system with which it is used. Above all, it is a true electronic instrument, not just an "electronic version" of a familiar string, reed, or percussion instrument. Its tone is unlike that of any conventional instrument.

A musician playing a theremin seems almost like a magician, for he can play a musical selection without actually touching the instrument itself! As he moves his hands back and forth near two metal plates, he seems to "conjure up" individual notes at any desired volume; he can "slide" from one musical note to another with ease, can produce tremolo and vibrato effects at will, and can even sound notes which fall outside the standard musical scale. He can play tunes or melodies, produce unusual sound effects, or can accompany a singer or another instrument—all by means of simple hand movements.\*

The theremin is ideal for amateur as well as professional musicians and can be used for "fun" sound effects as well as for serious music. It makes a wonderful addition to the home recreation room, and can be used equally well by rock'n' roll groups or larger bands. Theatrical groups find it just the thing for producing eerie and spine-tingling background effects to accompany mystery or horror plays, and for the budding scientist or engineer, it is an excellent Science Fair project.

The typical theremin has two r.f. oscillators, one having a fixed, the other a variable, frequency, with their output signals combined in a mixer/amplifier stage. At "tune-up," the oscillators are preset to "zero beat" at the same frequency. The frequency of the variable oscillator is controlled by an external tuning capacity—the "antenna"—which is a "whip" or simple metallic plate.

As the musician's hand is moved near this antenna, the variable oscillator shifts frequency and a beat note is set up between the two oscillators. The pitch is proportional to the difference in frequency between the two oscillators. This beat note, amplified, is the theremin's output signal. The more advanced theremin designs—such as the version presented here—use a third oscillator to control output volume and two antennas. This theremin also uses a unique FET volume, and a FET output stage. See Fig. 1.

## Construction

Except for the two control antennas, power switch S1, and battery B1, all components are assembled on a printed circuit board as shown full-size in Fig. 2(B). An insulated jumper is required between C15 and R20 as shown in Fig. 2(B) and Fig. 3. Mount the PC board in a suitable cabinet with four spacers (see Fig. 3), making sure that suitable holes are drilled in the cabinet or through a dialplate to accept the tuning-slug screws of L2 and L4. Coils L1 and L3 are mounted on small L-brackets; initially, these brackets should be adjusted so that L1 is at right angles to L2 and L3 at right angles to L4. Switch S1 is also mounted on the cabinet or

---

\* Nearly everyone who has ever watched television or attended a motion picture has heard music and background effects produced by a theremin, yet relatively few could recognize the instrument, and fewer still have had the chance to own or play one. With its astounding tonal and dynamic ranges, it has been used to produce background music and special effects in scores of science-fiction, fantasy, horror, and mystery shows.

dialplate, in the area of the L2 and L4 slug screws, while the battery is secured to the cabinet wall.

Ordinary copper-clad circuit board can be used to make up the pitch and volume control antennas. Although the author's units are equilateral triangles approximately 9" on a side—almost any other design will do—shape is not critical. If desired, the upper surface of the antennas may be covered with a colorful material (see cover photo).

The antennas are mechanically mounted on an electrically conducting support. The ones used by the author, (see Fig. 4) were six-inch lengths of 3/4" aluminum pipe with appropriate mounting flanges. The antennas were attached to the pipe with conduit plug buttons soldered to the bottom of each antenna. The flanges of the buttons should make a good friction fit to the pipe. A solder lug for connection to the PC board is placed under one of the pipe support mounting screws as shown in Fig. 3.

Connect the negative lead of the battery to terminal B on the PC Board; then connect the positive battery lead, via S1, to terminal A. The center lead of the audio output coaxial cable is connected to terminal C on the PC board, while the associated braid is soldered to the ground foil. Connect the volume control lead and one lead from L3 to the proper hole on the PC board (see Fig. 3), then connect the pitch control lead and one lead of L1 together and solder to the hole on the PC board. The other ends of both coils are soldered to the ground foil of the PC board.

## Tuning

Although the theremin is used with an external audio amplifier and speaker, no special test equipment is needed for the tuning adjustments. The procedure is as follows.

1. Temporarily short Q6's gate and source electrodes together, using either a short clip lead, or a short length of hookup wire, tack-soldered in place.
2. Preset the coil (L1, L2, L3, and L4) cores to their mid-position.
3. Connect the theremin's output cable to the input jack of an audio amplifier (with speaker)—a guitar amplifier is ideal. Turn the amplifier on, volume up to nearly full.
4. Turn the theremin on by closing S1 and adjust L2's slug (keep hands or other parts of the body away from the pitch antenna) until a low frequency growl is heard from the speaker.
5. Turn the theremin off and remove the short from Q6.
6. Turn the theremin back on and adjust L4's slug until a point is found where the growl is heard from the speaker. Then adjust L3's stud until the sound is reduced to near zero. This setting, although somewhat critical, will be stable once obtained.
7. Finally, adjust L2's slug until the growl becomes lower and lower in pitch, finally disappearing as "zero beat" is reached.

With the coils properly adjusted, no output signal will be obtained unless the operator's hands are moved near the *pitch* and *volume* control plates *simultaneously*. As the operator approaches the *pitch* control plate, a low-frequency note should be heard increasing in pitch as the hand moves nearer and, finally, going higher and higher and beyond audibility as the hand almost touches the plate. As the operator puts his hand near the *volume* control, a low level signal should be heard, increasing in amplitude until maximum volume is attained just before the plate is touched.

After the initial adjustments, L2 and L4 can be readjusted from time to time (using the front panel knobs) as needed to correct for minor frequency drift. In any case, a preliminary check of adjustment is always desirable whenever the theremin is to be used for a performance.

One further adjustment is optional. Coil L1's positioning with respect to L2 will determine, to some extent, the shape of the output waveform and, hence, its harmonic content. The mounting bracket supporting L1 can be adjusted to reduce the mutual coil orientation to less

than 90 degrees if a greater harmonic content is desired. However, as the angle is reduced, low-frequency notes may tend to become pulse-like in character.

## Installation

A guitar or instrument amplifier is an ideal companion unit for the theremin; either one allows bass or treble boost, as desired, and fuzz (distortion) or reverberation (if these features are incorporated in the amplifier's circuit). Simply provide a suitable cable plug and connect the theremin's output cable to the amplifier's input jack.

It is not necessary to purchase a special amplifier. The theremin's output signal level is sufficient to drive most power amplifiers to full output without additional preamp stages. The instrument can be used, for example, with a monaural version of the "Brute-70" amplifier described in the February, 1967 issue (of *Popular Electronics*).

If the theremin is used in conjunction with a power amplifier which does not have a built-in gain (or volume) control, a "volume level" control should be added to its basic circuit to prevent accidental overdrive. This can be accomplished quite easily by replacing source load resistor R16 (Fig. 1) with a 10,000-ohm potentiometer.

## Operation

The results obtained depend more on the ability of the operator than on built-in limitations within the unit itself. A good "ear" for music is a must, of course, but, in addition, a moderate amount of skill is required, particularly in finger or hand dexterity and movement. The latter is learned only through practice. For a start, here are the basic techniques.

*To sound an individual note*, first move the "pitch" control hand to the proper position near the *pitch* antenna (as determined by practice) to sound the desired pitch. Next move the "volume" control hand *quickly* to the proper position near the *volume* antenna to sound the note at the desired level, then away after the proper interval to sound an eighth, quarter, half or full note.

*To sustain a note*, hold both hands in position. The note volume may be increased slowly by moving the "volume control" hand *slowly* nearer the *volume* antenna, reduced by moving it slowly away.

*To "slide" from one note to another*, hold the "volume hand" fixed in position and move the "pitch hand" nearer (or away from) the pitch antenna plate.

*To produce a vibrato effect*, hold the "volume hand" fixed in position and shake—or tremble—the "pitch hand" at the desired rate.

*To create a tremolo effect*, hold the "pitch hand" fixed in position and vibrate—or tremble—the "volume control" hand.

*Tremolo and vibrato effects* can be produced by simultaneously rapidly moving both hands back and forth.

If you've used triangularly shaped control plates in your instrument (as in the model shown), you'll find that a given hand movement has less effect on operation near the narrow (pointed) end of the triangle than near its broad base.

Practice is important!

=====[30]=====

## How It Works

Transistors Q1 and Q2 are the variable and fixed "pitch" oscillators respectively, while Q4 serves as the "volume" oscillator. Essentially similar circuits are used in all three oscillators, so only one (Q1) will be described here. Base bias is established by resistor voltage divider R1 and R2, with the former bypassed for r.f. by C3. Resistor R3 serves as the emitter (output) load. The basic operating frequency is determined by the tuned circuit of L1 and the combination of C1 and C2.

In the case of Q1 and Q4, their tuned circuits are also connected to external "antennas." When these antennas are "loaded" due to body capacitance (the presence of a hand near the antenna), this "load" is reflected to the tuned circuits as a capacitive change which, in turn, alters the frequency of oscillation. Because Q2's circuit uses no "antenna," its frequency remains constant at all times.

In operation, Q1's r.f. output signal is coupled to mixer/amplifier Q3 via coupling capacitor C5—while Q2's signal is coupled to Q3 via C10. If these two oscillators (Q1 and Q2) are at the same frequency, then there will be no resultant "beat" present at the collector of Q3. However, since Q1's frequency is determined by how close the operator's hand is to the "pitch" antenna, the resultant beat frequency will vary as the distance between the hand and antenna varies. Because the mixing action of Q3 produces both r.f. and audio beats, capacitor C12 is used to bypass the r.f. components and prevent them from appearing at the collector of Q3. The resultant audio beat is passed, via the volume control circuit, to the FET output stage, Q7.

Oscillator Q4 (the "volume" oscillator), like "pitch" oscillator Q1, has its frequency of oscillation determined by the amount of hand capacitance near its "antenna." The r.f. signal at the collector is coupled via C20 to another tuned circuit consisting of L4 and C22. The r.f. signal across this second tuned circuit is rectified by diode D1 and applied to the base of d.c. amplifier Q5. Thus, the d.c. voltage level present at the collector of Q5 is a function of the amount of r.f. present on L4-C22. This level is at its maximum when the L4-C22 tuned circuit is at the *same* frequency as the Q4 collector tuned circuit.

In practice, however, the frequency of Q4's tuned circuit is made to be *slightly higher* than the L4-C22 frequency. As a result, very little d.c. signal is passed to the base of Q5. This means that the voltage at the collector of Q5 is at a maximum. If the frequency of Q4's tuned circuit is reduced, when a hand is placed near the "volume" antenna, the base current applied to Q5 increases, causing the collector voltage to drop.

The unique volume control consists of FET Q6, connected in shunt with the audio signal flow. The audio signal at the collector of Q3 passes through d.c. blocking capacitor C13 and is also isolated (for d.c.) from Q7 by C14. Resistor R13 and FET Q6 are arranged as a voltage divider. If the gate voltage of Q6 is highly positive, then the FET acts as a low resistance between R13 and ground, greatly reducing the signal level allowed to pass to Q7. As the gate of Q6 goes less positive, the effective resistance of Q6 increases and the level of audio signal to Q7 increases.

The voltage at the collector of d.c. amplifier Q5 is connected to the gate of Q6. As this voltage level is determined by the frequency of Q4, the operator can readily adjust the output volume by changing his hand capacitance to the "volume" antenna. The variable pitch variable-volume audio signal is coupled to an external audio amplifier via FET Q7. A FET is used for Q7 because its very high input-impedance (a couple of megohms) will not affect operation of FET Q6. If desired, the source resistor of Q7 can be changed to a similar valued potentiometer.

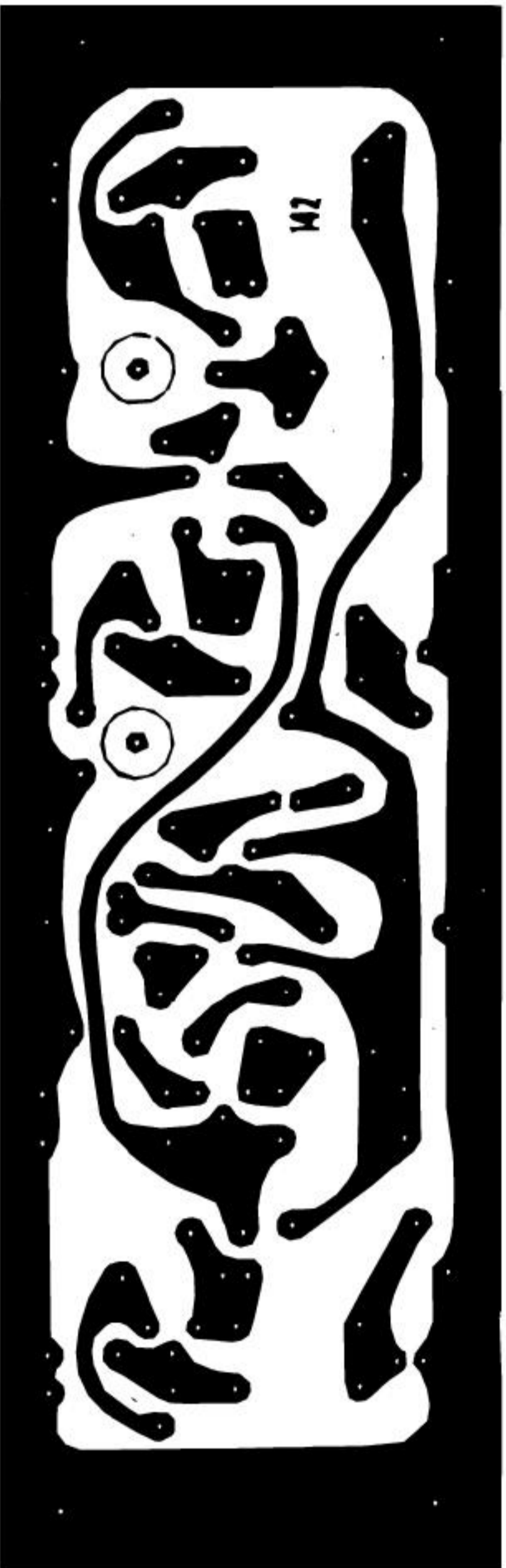
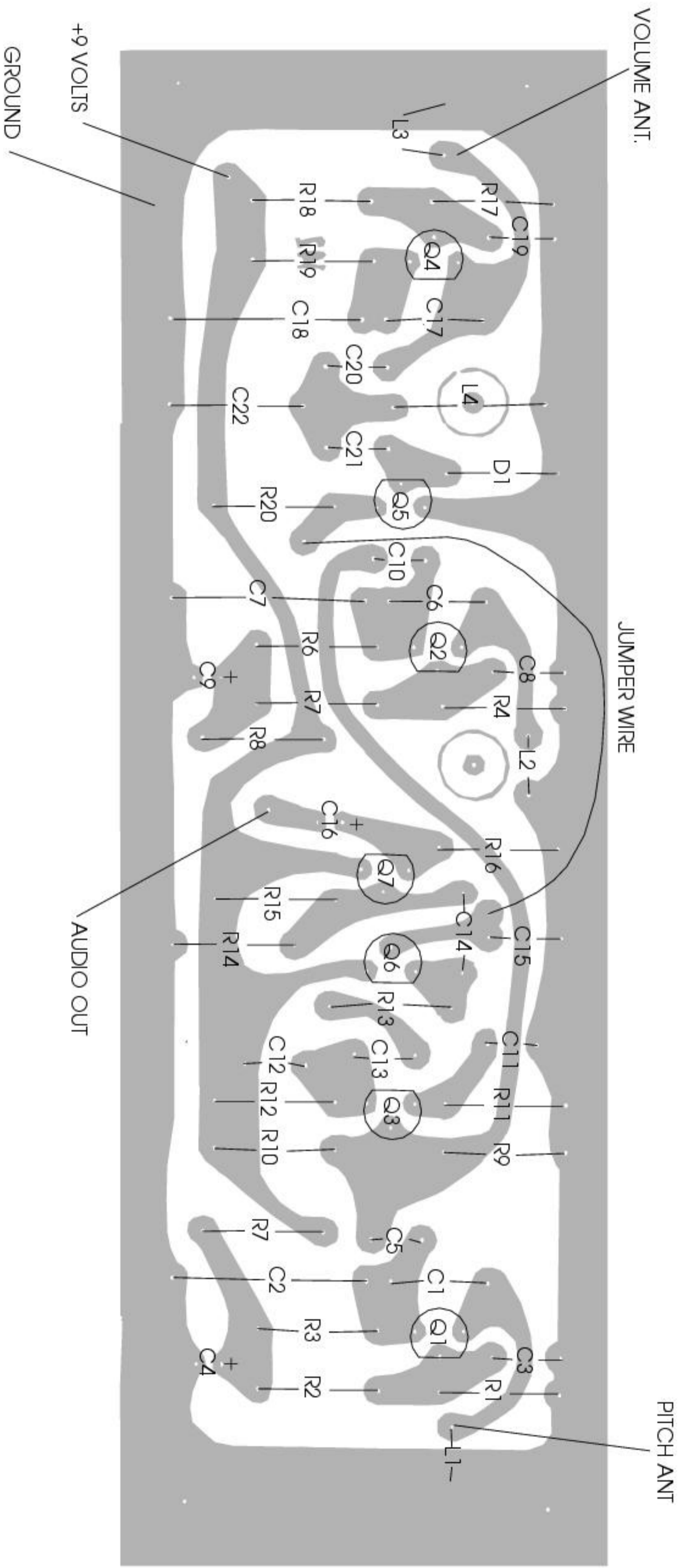

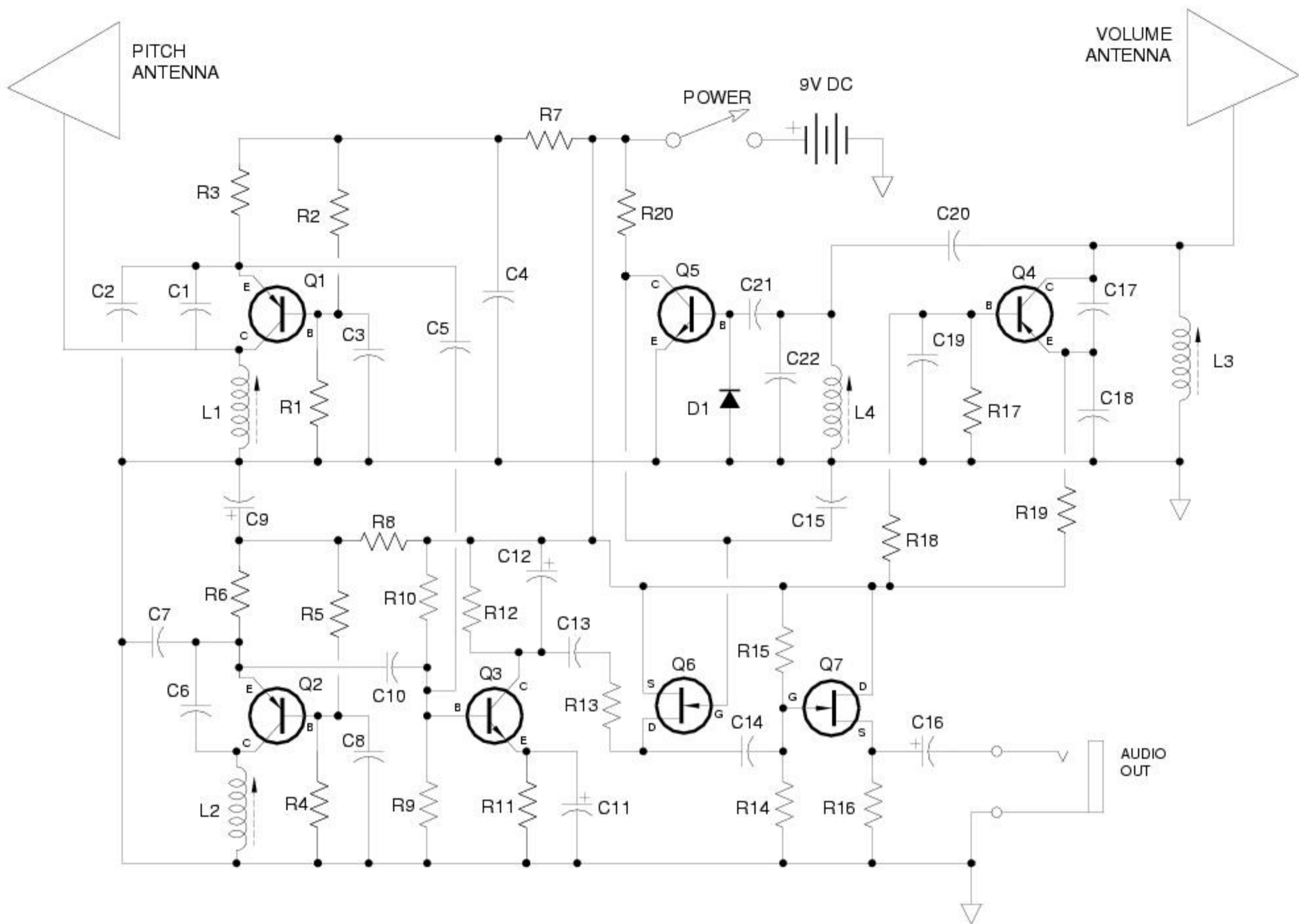

B1  
 C1, C6  
 C2, C7, C17, C22  
 C3, C8, C19  
 C4, C9  
 C5, C10  
 C11  
 C12, C14, C15  
 C13  
 C16  
 C18  
 C20, C21  
 D1  
 L1, L2, L3, L4  
 Q1, Q2, Q4  
 Q3, Q5  
 Q6, Q7  
 R1, R4, R17  
 R2, R5, R18  
 R3, R6, R7, R8,  
 AND R11, R19  
 R9, R12, R16, R20  
 R10, R13  
 R14, R15

9-VOLT BATTERY  
 390pF POLYSTYRENE CAPACITOR  
 0.001uF POLYSTYRENE CAPACITOR  
 0.1uF DISC CERAMIC CAPACITOR  
 10uF, 15V ELECTROLYTIC CAPACITOR  
 60pF POLYSTYRENE CAPACITOR  
 200uF, 15V ELECTROLYTIC CAPACITOR  
 0.001uF DISC CERAMIC CAPACITOR  
 0.01uF DISC CERAMIC CAPACITOR  
 5uF, 15V ELECTROLYTIC CAPACITOR  
 0.01uF POLYSTYRENE CAPACITOR  
 4.7pF POLYSTYRENE CAPACITOR  
 1N34A DIODE  
 50-300uH ADJUSTABLE COIL  
 MPS3638 TRANSISTOR (MOTOROLA)  
 MPS3708 TRANSISTOR (MOTOROLA)  
 TIS-59 N-CHANNEL FET (TEXAS INST)  
 47K 1/2W 10% RESISTOR  
 33K 1/2W 10% RESISTOR  
 1K 1/2W 10% RESISTOR  
 10K 1/2W 10% RESISTOR  
 100K 1/2W 10% RESISTOR  
 4.7MEG 1/2W 10% RESISTOR